



## Pinewood Derby Mania!

A CUB SCOUT PHENOMENON



November 1, 2011

Scouting Friends,

The Davis Anderson Memorial Allohak Council Pinewood Derby—the Council Championships—the big kahuna—is set for Saturday, February 4, 2012, at the Grand Central Mall. Our 40<sup>th</sup> Annual event promises to be bigger and better than ever before. Enclosed in this packet is your pack's registration form for this year's Derby. **Please take the time to review all sections of this packet** with all your Scouts; all your Pack parents; your Pack Committee; your COR and your Unit Commissioner. Help us grow this fun Scouting event!

For the 2012 race, the Race packet is on the Allohak Council Website.

Your help is needed this year in passing out and reviewing all the enclosed Derby information at Cub Scout Roundtables, training sessions, den meetings, pack meetings, etc. We ask that you start as soon as possible reviewing and passing out all this information. Your help in reviewing and passing out all this information will make Derby day go smoother and be a more enjoyable, fun experience for the Scouts, their families and the volunteers. We need to continue this education process each and every year throughout all areas of the Allohak Council.

If you would like any member of the Pinewood Derby Committee to attend any of the Roundtables, training sessions, den meetings, pack meetings, etc., to help with the Pinewood Derby Information, please give me a call. Please plan ahead. Help us grow this event.

Please remember that one of the best ways to prepare for Derby day and to keep Derby day fun, is make sure all the Scouts and their families have a copy of the Derby rules and that they understand the Derby rules and the true intent and purpose of the Pinewood Derby. The 2012 rules are included in this packet. **The council office will be passing out a copy of the rules with each race car kit sold.**

Several members of our Pinewood Derby Committee have volunteered to attend meetings and do some preliminary inspection of the Scouts cars. This team can bring the Pinewood Derby measuring devices with them to your Pack meeting. We will not be able to bring any scales to weigh the cars. We hope that by offering this service to the Packs, we will be able to reduce the number of Scouts who spend an excessive amount of time in the Pit Area at the Derby working on their cars to conform to the official Derby rules.

If you would like a team to visit your Pack meeting or clinic, please try to contact me at least 2 weeks before your event so we can get you on the calendar. **Please note that the official inspections by the inspectors at the Derby on February 4 are final.**

**Excessive time in the pit area causes us to run behind scheduled racing times.** Please remember **the scales at the Derby weigh in grams** (not ounces). A set of gram scales is available at the Scout office to weigh cars. Please note that these scales do not leave the office for any reason and these are not the official PWD scales. ISO/A2LA certified/calibrated scales are used on Derby Day. Remember—gram scales only,

To help reduce time in the pit area, we encourage each pack to have a builder's clinic to build cars and go over all the PWD rules with the racers and their families. We need to continue to educate the racers and their families on the purpose/reason of each rule. **Grams scales only** as these clinics are suggested. Perhaps you could combine with an area pack to have this event. Many places such as Wood Crafters in Parkersburg may be a resource for your pack. If you would like one of the inspectors to attend your clinic, please let us know.

**The PWD is a great, fun event. We want each and every Scout in each and every Pack in the entire council to race at this event.** We encourage each pack to bring their banner/flags and have PWD songs and cheers for their packs. Enthusiasm is encouraged! **We also encourage you to encourage all packs in your area to participate in this council event.** On race day, please make sure each racer has a name tag with their name and Pack number. Please encourage your mayor and area celebrities to race at the noon mayors/celebrities race.

PWD packets for each pack will be prepared the week before the PWD. If you have items that you would like to have included in the packets, you must get these items to me no later than January 25, 2012. I will need 60 copies of each item. This is a great way to advertise any upcoming Cub events, day camps, etc., in any area of the Council.

**The registration deadline is Wednesday, January 25, 2012 at 5pm** and will be strictly adhered to. No add ons or late registrations will be accepted for any reason as our volunteers are working hard to give all the Scouts and their families a fun quality event.

Please feel free to contact me if you have any questions, ideas or suggestions.

With heartfelt thanks—

**Kathy**

Kathy Anderson Wise

Allohak Council Pinewood Derby Volunteer Coordinator

Home: (304) 295-3373 [kloua@suddenlink.net](mailto:kloua@suddenlink.net) Cell: (304) 482-7576

The purpose of the Pinewood Derby is to help the Cub Scout build a team relationship with their parent or helper, experience the sense of accomplishment, learn new skills, the excitement of competition, learn Win/Lose good sportsmanship, **and to have fun.** The model cars are made of wood to specified dimensions, created, carved, assembled, and decorated by Cub Scouts under the guidance of the parents or helpers. Please stress the true purpose and meaning with all your Scouts and parents several times.



## SUGGESTIONS FROM YOUR ALLOHAK COUNCIL PINWOOD DERBY COMMITTEE--2012

- IN NOVEMBER OF EACH YEAR, REVIEW THE CURRENT DAVIS ANDERSON MEMORIAL ALLOHAK COUNCIL PINWOOD DERBY RULES AND INFO PACKET WITH ALL YOUR SCOUTS; THEIR FAMILIES; YOUR PACK COMMITTEE; YOUR COR AND YOUR UNIT COMMISONER. MAKE SURE EACH RACER AND PARENT HAS A COPY OF THE RULES AND UNDERSTANDS THE RULES. REVIEW THE RULES AT EACH PACK AND DEN MEETING PRIOR TO THE DERBY. RULES ARE ON THE WEBSITE AND AVAILABLE AT THE OFFICE.
- DERBY RULES MUST BE FOLLOWED. PERIOD.
- **YOU MUST USE (SEE RULES)** ONLY THE OFFICIAL PINWOOD DERBY KIT. KITS AND MATERIALS SOLD AT HOBBY SHOPS/INTERNET DO NOT CONFORM TO DERBY RULES AND GUIDELINES. NON CONFORMING CARS CAN CAUSE RACE DELAYS SINCE TIME IN THE PIT AREA WOULD BE REQUIRED TO MAKE THE CAR CONFORM TO THE RULES. **EXCESSIVE TIME IN PIT AREA CAN PUT US BEHIND SCHEDULE ON RACE TIMES. BE PREPARED. INSPECT/WEIGH ALL CARS BEFORE 2.4.2012 TO MAKE SURE THEY ADHERE TO THE RULES. THANK YOU!**
- DO NOT USE ANY TYPE OF TAPE TO ATTACH WEIGHTS TO CARS. REVIEW THE RULES.
- HAVE CREATIVE CAR AWARDS DURING YOUR PACK RACES. HAVE DADS/PARENTS/SIBLINGS MAKE THEIR OWN CARS AND HAVE THEIR OWN RACE AT YOUR PACK RACES. GIVE AWARDS FOR THESE RACES.
- REVIEW THE RULES AND TRUE PURPOSE AND TRUE MEANING OF THE PINWOOD DERBY WITH ALL YOUR SCOUTS AND THEIR FAMILIES AT LEAST 2 PACK AND DEN MEETINGS PRIOR TO THE DERBY. HAVE FUN!!!
- HAVE A PRE-DETERMINED MUSTER POINT IN ANOTHER PART OF THE MALL AWAY FROM THE REGISTRATION STORE BEFORE THE ALLOHAK COUNCIL PINWOOD DERBY. MAKE SURE ALL SCOUTS AND THEIR FAMILIES KNOW WHERE THIS IS AND WHAT TIME THEY ARE TO BE THERE. MAKE SURE THEY UNDERSTAND THAT IF THEY ARE LATE THEY WILL NOT BE ABLE TO RACE PER DERBY RULES. NO SUBSTITUTION OF RACERS IS ALLOWED.
- THE 2012 PINWOOD DERBY WILL BE ON 2/4/2012. REGISTRATION DEADLINE WILL BE 1/25/12 AT 5PM. **ONLY THE OFFICIAL REGISTRATION FORM WILL BE ACCEPTED.** ALL REGISTRATION FORMS MUST BE PRINTED AND LEGIBLE. NO REGISTRATION WILL BE ACCEPTED AFTER 5PM ON WEDNESDAY, JANUARY 25, 2012.
- ALL SCOUTS THAT ARE RACING MUST BE REGISTERED SCOUTS WITH THEIR DUES PAID PRIOR TO THE DERBY. THIS IS THE CUBMASTERS RESPONSIBILITY TO ENSURE THAT THIS IS TAKEN CARE OF BEFORE THE REGISTRATION FORM IS TURNED INTO THE OFFICE.
- AS A CONSIDERATION TO MALL MERCHANTS, ASK PARENTS AND FAMILIES NOT TO GATHER IN THE AREA IN FRONT OF THE REGISTRATION STORE. ASK THEM TO PLEASE MEET THEIR SCOUTS AT THE TRACK AREA.
- BE READY AND ORGANIZED DERBY DAY. THIS HELPS THE VOLUNTEER STAFF A GREAT DEAL.
- A SET OF GRAM SCALES IS AVAILABLE AT THE SCOUT OFFICE TO WEIGH CARS AS A HELP TO ALL SCOUTS. THE SCALES MAY NOT BE TAKEN OUT OF THE SCOUT OFFICE FOR ANY REASON. THESE ARE NOT THE OFFICIAL DERBY SCALES.
- **THIS IS THE COUNCIL PWD.** MENTOR PACKS IN YOUR AREA AND ENCOURAGE THEM TO PARTICIPATE IN THIS GREAT COUNCIL EVENT—THE COUNCIL CHAMPIONSHIPS!
- NEED HELP, HAVE SUGGESTIONS, PLEASE LET US KNOW.
- THANK YOU!
- **Come race with the pack each year and catch the spirit—the Scouting spirit!**

MARK YOUR CALENDAR FOR 2012—FEBRUARY 4, 2012 PWD  
REGISTRATION DUE 1/25/2012

By Steve Lange

THEY SAY SMELL IS PERHAPS the strongest of the senses when it comes to jogging memory. I know now this is true. Recently I had the chance to smell, simultaneously, pancakes with powdered sugar, sawdust, and horse manure.

I will not mention the name of the restaurant.

But to an ex-Cub Scout who was only an errant-snowball-to-the-eye-of-a-den-mother away from Scouting greatness, these smells can mean only one thing - pinewood derby race days.

Pinewood derby is an annual event in which Cub Scouts race wooden model cars down a sloped track for fun and camaraderie.

The Cub Scout race days I remember included a pancake breakfast (with powdered sugar), some Scout leaders on horseback of all things, and some sort of orange drink for refreshment.

The competition featured race cars the Cub Scouts had built (with dad or mom assisting) from special kits received a few weeks before. The car's construction is supposed to be completed by the Cub Scout. The parent's role is to guide, explain, advise.

But there always was a group of well meaning but overcompetitive parents who got caught up in the trophies and the ribbons and the winning. This could result in a competition among fathers the likes of which had not been imagined since Nero's Rome, or possibly Sparta on a bad day. It could become an intense Circus Maximus in which fathers relived entire childhoods in a single day.

The children of these parents rarely got to so much as touch their derby car, what with the constant comings and goings of the outsourced design teams and think tanks of retired Peugeot engineers.

I was one of the luckier kids. I got to put on a coat of primer. I was allowed to affix a decal. But as for the racer's actual design and construction, my father, if it was possible, took everything a step too far.

My dad is an engineer. An automotive engineer. A few years earlier, he had let my older brother handle and even sand his derby car. The son-and-father team was defeated in the finals in a finish so close that my father will dispute it on his deathbed.

"It was so close," I heard him tell my mother, "that he might've won if he hadn't sanded that nose so much."

My brother went home elated to be second out of many. My father brooded for four years. He would not, he vowed, be defeated again.

Our garage was transformed into a workshop. Blueprints were thumb tacked to the wall. Extra electrical outlets were installed. For the first few days of the car-building project, I sum was out there, holding the light, handing him tools. He used a jigsaw, 1500 grit sandpaper, and something called a lathe.

Despite my lack of in, the project still a learning process. Near the end of week one, my father lost a thumbnail to a chisel and I heard words and combinations of words possibly never before uttered. (At no time, I learned, at an early age, is freedom of speech more important than when man hits thumb with hammer.)

Come race day, we arrived prepared. My father and I skipped the pancakes in favor of checking out the race pairings board, scoping out the competition.

It was there we saw my friend Danny. I knew that Danny's dad didn't overdo it on his car. Danny's dad didn't ever do anything with him - his dad was never around. His mom was always working, taking care of the family. And Danny was too proud to ask anyone else for help.

He looked at my car's carrying case, a leather-lined toolbox. He carried a shoe box and opened it to proudly show me his racer. It had been whittled from the wooden block into an oblong shape meant to be a bus. It had no lead weighting, the wheels were off-balance, and it was colored with an orange felt-tip marker.

"I built it myself," he said.

In Danny's first race his bus jiggled down the slope and came to an agonizing stop a yard short of the finish. He had to pick up his racer off the track.

We won our first race by 15 feet.

The format was double elimination, and we checked the pairings board for the next victim. It was to be Danny.

My stomach started to hurt.

Having winners meant there also had to be losers. And by winning, my dad would be a step closer to exorcising his demons.

But the losers were supposed to be other dads who weren't as smart as mine, not dad-less 9-year-olds who didn't have access to precision machinery and an aerodynamically efficient painting process.

So I feigned illness, blaming bad pancakes. My father reminded me that we hadn't eaten yet.

We went our separate ways, planning to reunite when our next race was called. I sulked. I considered all the ways kids get out of things. I didn't want to race Danny.

When I moped back to the track, my father was already there, waiting. He didn't have our car carrying case. "Can't race," he said. "I dropped the car and broke a wheel off." I think I actually skipped to our truck to check the racer's condition.

But the car was intact. It hadn't been damaged.

I'm not sure where that car is today, and I don't think I ever took home so much as a ribbon in my next few pinewood derbies.

But I do remember that the next weekend my dad taught Danny and me how to use a lathe.

*Steve Lange is former editor of Sault Ste. Marie (Mich.) Evening NewsSault Sunday Edition, in which a version of this article originally appeared.*



Copyright © 1997 - Scouter Magazine

The Smell of Victory!  
Please share this with your pack!

## **SPORTSMANSHIP**

Pinewood derby racing requires participants to learn two main things: **the craft skills necessary to make your car** and the **rules** that must be followed. There is also a third part to the competition that's very important---sportsmanship.

**This has to do with how you act and behave while participating in the derby.**

The first thing to remember about sportsmanship is that everyone's skills are a little different. Some people are better than others at certain skills. You may be good at one thing but not good at another. This doesn't mean you are a good person one time and not good another time. You can always be a good person, whether or not you have good skills for racing.

Remember,  
you and your friends are individuals first and racers second.

**This idea is called having respect for each other.**

The second thing to remember is to follow the rules. Without rules, there would not be a pinewood derby. You will never know if you are really good at something unless you follow the rules.

**This is sometimes called being fair and honest.**

The third thing to remember about good sportsmanship is that there are winners and losers in every competition. You know this when you choose to compete. There are times when you will win and be happy, and times when you will lose and be unhappy. Being a winner is easy but being a loser is sometimes hard. To be a good sportsman, you must be able to say "I did my best" and be satisfied with the results. If you win you must not gloat.

(From Cub Scout Derby Grand Prix Pinewood Derby Guide book)

## *Coaching Hints for Parents*

(From *Cub Scout Derby Grand Prix Pinewood Derby Guide* book)

- Review with your son the “Getting Started” chapter of the guidebook.
- Help your son plan a schedule to prevent a last-minute project and allow time for him to do his best.
- Help your son understand the rules, the reasons for the rules and specifications found in the kit and any rules developed by your local pack derby committee.
- As your son chooses his favorite design, help him trace it on the block of wood from the kit.
- Guide him in the use of tools in the shaping of the model and encourage him to sandpaper the model to a smooth finish.
- Help your son feel that this is a joint project, with him doing much of the work.
- Help your son understand that “doing your best” is as important as having the fastest model.
- Feel a sense of pride and satisfaction when the model and race are finished. Share it with your son. You both have earned it.
- Understand that the leaders may need your help. If you have the interest and time, you might contact the leaders and volunteers to help or judge the pack’s big race.
- Spending time with your son, helping him to “do his best” will be remembered long after the race is finished.



PACK #	# REGISTERED	RACE TIME	TRACK
LEADER DERBY DAY			
PRE-DETERMINED MUSTER LOCATION			

PACK LEADER RACE DAY INFO 2/4/12  
PLEASE BE ON TIME AND STAY ON TIME.

1. IF YOU ARE THE LEADER WHO WILL BE TAKING THE PACK INTO THE REGISTRATION ROOM, YOU MUST WEAR THIS NAME TAG. ONE LEADER PER 20 RACERS IN EACH PACK. TURN YOUR NAME TAG INTO THE TRACK OFFICIAL AT THE TRACK AFTER YOUR PACK HAS RACED.
2. HERE ARE YOUR REGISTRATION CARDS. MAKE SURE EACH REGISTERED RACER HAS HIS CARD & CAR IN HAND WHEN YOUR PACK IS CALLED. **ALL CUBS MUST HAVE A NAMETAG.**
3. KEEP THE CARDS OF THE BOYS WHO HAVE NOT SHOWN UP IN A SEPARATE PILE. GIVE THESE TO THE RACE OFFICIAL WHEN CALLED. BOYS WHO ARE SUBS GO TO BACK OF THE LINE.
4. PACK WILL BE CALLED TO THE REGISTRATION ROOM ABOUT 30 MINUTES BEFORE YOUR SCHEDULED RACE TIME TO BE INSPECTED. BE READY & ORGANIZED. AFTER LAST CALL FOR **YOUR PACK, NO MORE RACERS (LATE ARRIVALS/NO SHOWS)** WILL NOT BE PERMITTED TO RACE. THIS IS NECESSARY SO THAT YOUR PACK RACE BRACKETS CAN BE PREPARED.
5. NO PARENTS OR ADDITIONAL PACK MEMBERS ARE PERMITTED IN THE REGISTRATION ROOM. IF A RACER HAS A PROBLEM WITH A CAR, A RACE OFFICIAL WILL COME TO THE FRONT TO FIND THE PARENT. THE SCOUT WILL NOT BE PERMITTED TO GO OUTSIDE THE REGISTRATION AREA ALONE. **THE INSPECTOR WILL KEEP THE CARD & CAR UNTIL ASSISTANCE FOR THE RACER IS LOCATED.**
6. PLEASE ENCOURAGE THE PARENTS & FAMILIES OF THE RACERS TO MEET THE PACK AT THE TRACK. PLEASE TRY TO KEEP THOSE REMAINING IN FRONT OF THE REGISTRATION AREA TO A MINIMUM.
7. **LEADERS, PARENTS AND SCOUTS WILL NOT BE PERMITTED TO BRING BOXES, TOOL KITS, CAMERA CASES, FANNY PACKS, COATS, BACKPACKS OR PURSES IN THE REGISTRATION AREA. CUBS ARE ENCOURAGED TO LEAVE ALL PERSONAL ITEMS (COATS, ETC.) WITH THEIR PARENTS.**
8. **NO LUBRICANTS OF ANY KIND ARE PERMITTED IN THE MALL. PERIOD. SEE THE RULES.**
9. A COPY OF THE DERBY RULES IS IN YOUR PACKET.
10. REVIEW THE ENTIRE CONTENTS OF YOUR PACKET WHEN YOU HAVE TIME.

DO YOU UNDERSTAND ALL THE ABOVE? DO YOU HAVE ANY QUESTIONS OR SUGGESTIONS?  
**THANK YOU FOR YOUR HELP!**  
**PLEASE RETURN YOUR LAYNARD AND NAMETAG TO THE REGISTRATION DESK AFTER YOUR RACE.**

**Please remember...we are all volunteers..**



**ALLOHAK COUNCIL, BSA**  
**OFFICIAL COUNCIL PINEWOOD DERBY RULES**  
 Revised: 11.1.2011 for 2012 Events by the PWD Committee



Davis Anderson Memorial Pinewood Derby  
 The Allohak Council Championships--Parkersburg, WV--Grand Central Mall -- February 4, 2012

CUBMASTERS MUST REVIEW RULES AS AN EDUCATION PROCESS AT PACK AND DEN MEETINGS IN BOTH DECEMBER AND JANUARY WITH PARENTS/SCOUTS. AT THE SAME TIME IT IS SUGGESTED THAT YOU REVIEW THE TRUE MEANING AND PURPOSE OF THE PWD.

**A COPY OF THESE RULES MUST BE GIVEN TO EACH PARTICIPANT BEFORE BUILDING THE GRAND PRIX/PINEWOOD DERBY RACER.**

All cars must conform to the inspection standards listed to be allowed to race. The inspectors ruling on race day is final.

**ALL BOYS ARE REQUIRED TO BUILD A COMPLETE NEW CAR EACH YEAR**

Wheels and axles must be Official BSA Grand Prix Racer/Pinewood Derby Parts.  
Modified wheels and axles purchased from other sources, including internet sites, are not acceptable and are not to be used for any reason.

DO NOT ASSUME the width, length and height of a kit are standard.  
 The main body of the BSA Grand Prix Racer must be made of wood.

All ten (10) participants in the 2012 council's finals are required to return their 2012 car and 2012 trophy to the council office by December 1, 2012 for display at the 2013 event. When returned to the Council office, the car must be permanently mounted to the trophy. There will be no variance to this rule for any reason.

**CAR SPECIFICATIONS**

**(Note: Wheels and axles must be Official BSA Grand Prix/Pinewood Derby Racer Parts.)**

- S1. Overall width of body (car including wheels) shall not exceed 3 (three) inches.
- S2. Overall length of body (car including wheels) shall not exceed 7 (seven) inches.
- S3. The car (car including wheels and weights) must have a track clearance of a minimum of 3/8 inches.
- S4. The height of the car (car including wheels) will not exceed 3 (three) inches.
- S5. The weight shall not exceed **142 grams**. The scales at the derby registration are the official scales. Weight may vary from the scales that you use. If a car is overweight, the racer must reduce the car's weight to meet the rules. No weights may be added at inspection at the mall.
- S6. Car detailing is permitted as long as they do not exceed the maximum length, width, and height and weight specifications of the car.
- S7. The body of the BSA Grand Prix Racer must be made of wood.
- S8. Pinewood Derby Car must have a solid front end, meaning no slopes, no notches, no channels and no points on the car that would give an advantage at the starting line.

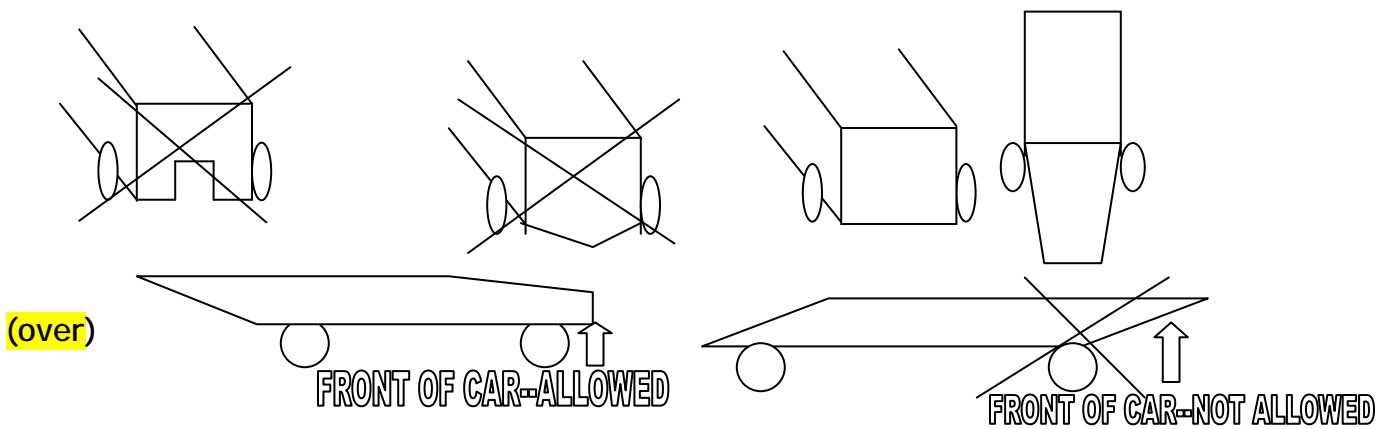

### CAR RESTRICTIONS

- R1. No adhesive tape of any type may be used on the car.
- R2. No loose materials of any kind are permitted on the car. The car may be hollowed out and built up to a maximum weight provided that it is built securely into the body.
- R3. Washers and bushings are prohibited on wheels. Any and all lubricants are permitted but must be applied outside the mall. Anyone possessing or found using any lubricants inside the mall will be disqualified immediately and will have all lubricants confiscated.
- R4. The wheels may not be reduced from their original size and weight. The wheels may be smoothed, but not tapered. Wheels and axles must be unaltered official BSA Grand Prix/Pinewood Derby Racer parts only. No hubcaps allowed. Required replacements on Derby day will be charged to the pack.
- R5. The car shall not ride on any type of spring or any type of guide.
- R6. The car must be freewheeling with NO starting device(s).
- R7. Mercury is prohibited as a weight.

### GENERAL RULES GOVERNING RACE

- G1. Each car must pass an inspection by the Official Inspection Committee at the Derby. All rules must be strictly adhered to. A pit area with tools will be available Derby Day to make Adjustments. The inspectors will disqualify those cars that cannot meet these specifications.
- G2. A Cub Scout must be present to race his own car. (NO SUBSTITUTES)
- G3. In the case of a tie, the racers will run again on the same lane.
- G4. After registration and inspection, only the Cub Scout may handle his car. No car boxes or containers of any type in the registration area.
- G5. No fanny packs, no tool kits, no boxes, no backpacks, no camera cases, no purses, no coats are permitted in the registration room, pit area or holding area.
- G6. Only one adult representative for each 20 Scouts will be allowed in the registration/holding area at any time. Make sure all your Scouts have a nametag with their name and Pack number.
- G7. All racers must be registered as a Tiger Cub, Cub Scout or Webelos Scout with the Boy Scouts of America. Office records will determine registration. Cubmasters are to ensure this prior to turning the official registration form.
- G8. All registrations for the Derby must be received by--5pm on Wednesday, January 25--2012. Registration deadlines will be strictly adhered to. No registration will be taken after the Registration date or on race day. Only the official registration form will be accepted. All registration forms must be printed and legible. Each pack will be issued a time to check-in for registration. Your pack will be notified by Email (and posted on the Council website) as to your official race time. It is the responsibility of the Cubmaster to inform each Scout and their parents in their Pack of their Pack's race time. Please adhere to these check-in times.
- G9. Remember, it's about having fun.

### DISQUALIFICATION

- D1. If a car loses a part twice in any heat. Should this happen once, the race will be stopped and the racer will have a chance to fix his car. Only the racer may work on his car.
- D2. If a car jumps the track twice in any heat.
- D3. If your car touches another car twice in any heat.
- D4. If a racer arrives after his pack has left the holding area to race.
- D5. If any part of the car extends beyond the starting pin.
- D6. If the car is modified after registration by anyone in any manner.

Questions or comments should be addressed to: 2012 Davis Anderson Memorial Pinewood Derby Coordinator.

### The purpose of the Pinewood Derby

is to help the Cub Scout build a team relationship with their parent or helper, experience the sense of accomplishment, learn new skills, the excitement of competition, learn Win/Lose good sportsmanship, **and to have fun.** The model cars are made of wood to specified dimensions, created, carved, assembled, and decorated by Cub Scouts under the guidance of the parents or helpers.

**We encourage all Cub Scouts in all Packs in the entire Council to race in this annual event.**



2012

PLEASE PRINT ONLY AND WRITE LEGIBLY WHEN FILLING OUT ALL SECTIONS OF THIS FORM  
*Required email--we require your email to get race info to you quickly.  
 Schedules and muster points are also placed on the Council website on Saturday after registration closes.*



**2012 ALLOHAK COUNCIL BOY SCOUTS OF AMERICA  
 40<sup>TH</sup> ANNUAL DAVIS ANDERSON MEMORIAL COUNCIL PINWOOD DERBY  
 COUNCIL CHAMPIONSHIP--FEBRUARY 4, 2012--GRAND CENTRAL MALL--VIENNA, WV**

PACK \_\_\_\_\_ DISTRICT \_\_\_\_\_ CUBMASTER \_\_\_\_\_ PHONE \_\_\_\_\_ EMAIL \_\_\_\_\_

LEADER DERBY DAY \_\_\_\_\_ PHONE \_\_\_\_\_ EMAIL \_\_\_\_\_

**\*\*PACK PRE-DERBY MUSTER LOCATION (will be assigned if not stated)** \_\_\_\_\_

LIST SCOUT NAME AS HE IS REGISTERED WITH THE COUNCIL.  
 IF THE SCOUT IS MORE FAMILIAR WITH HIS NICKNAME, PLEASE INCLUDE THAT INFORMATION IN PARENTHESIS.

1	17
2	18
3	19
4	20
5	21
6	22
7	23
8	24
9	25
10	26
11	27
12	28
13	29
14	30
15	31
16	32

All participants must be REGISTERED TIGER, CUB, OR WEBLOS SCOUTS with current fees paid.  
 Current rules & regulations of the BSA will define REGISTERED SCOUTS. Names will be checked pre-Derby.

**REGISTRATION DEADLINE---5PM, WEDNESDAY, JANUARY 25, 2012--This date will be strictly enforced.**

No add-ons or late registration will be accepted. It is the accountability and responsibility of the Cubmaster to turn in an accurate form on time.

\$5.00 X \_\_\_\_\_ PARTICIPANTS = \$ \_\_\_\_\_ ENCLOSED.

**FEES ARE TRANSFERABLE TO ANOTHER BOY BUT ARE NOT REFUNDABLE!  
 NO REGISTRATION/ADD-ONS WILL BE TAKEN AFTER DEADLINE OR ON RACE DAY!**

Send your official registration forms & fees to: Allohak Council--BSA/1340 Juliana St., Parkersburg, WV 26101

**CUBMASTERS--PLEASE CHECK TO INDICATE EACH ITEM WAS COMPLETED PRE-DERBY**

- ALL CARS WERE INSPECTED PRE-DERBY BY THE RULES TO PREVENT EXCESSIVE AMOUNTS OF TIME IN THE PIT AREA AT THE MALL
- INFO PACKET WAS RECEIVED & REVIEWED WITH ALL THE PACK & FAMILIES PRE-DERBY.
- THE TRUE PURPOSE & INTENT OF THE PINWOOD DERBY WAS REVIEWED AT JANUARY PACK MEETINGS.
- DERBY RULES WERE REVIEWED & PASSED OUT AT DECEMBER PACK/DEN MEETINGS AND REVIEWED.
- ALL RACERS WILL BE NOTIFIED OF THEIR RACE TIMES. ALL RACERS ARE REGISTERED SCOUTS AND FEES PAID.
- PRE-DETERMINED MUSTER POINT (& TIME) AWAY FROM THE REGISTRATION AREA WAS COMMUNICATED TO THE PACK.
- WE ENCOURAGE SCOUTS TO WEAR THEIR UNIFORMS TO THE DERBY.
- NAME TAGS ARE REQUIRED FOR EACH RACER WITH THEIR NAME AND PACK NUMBER.
- BOYS WERE INSTRUCTED IN THE PROPER HANDLING OF THEIR CARS AT THE DERBY.
- ENCOURAGED ALL PACKS AND EACH SCOUT IN EACH PACK IN YOUR DISTRICT TO PARTICIPATE IN THE COUNCIL PWD.
- REMINDED EVERYONE THIS IS ABOUT HAVING FUN.

*ENCOURAGE ALL PACKS IN YOUR DISTRICT TO PARTICIPATE IN THE COUNCIL EVENT.  
 WE ENCOURAGE EACH PACK TO SEND PUBLICITY TO THEIR LOCAL MEDIA ON THEIR PACKS PREPARATION FOR THE COUNCIL PWD.  
 WE ENCOURAGE ALL SCOUTING UNITS TO SEND PR TO THEIR LOCAL MEDIA AT LEAST 2 TIMES YEAR ON THE GREAT ACTIVITIES OF YOUR UNIT.*